

Uchwyty narzędziowe VDI do centr tokarskich CNC

VDI Toolholders for CNC Lathes
Werkzeughalter für CNC-Drehemaschinen
Державки VDI

DIN69880



UCHWYTY NARZĘDZIOWE VDI DIN69880 DO CENTR TOKARSKICH CNC

VDI TOOLHOLDERS FOR CNC LATHES

Spis treści / Index

Ilustracja / Picture	Nazwa produktu / Product name	Strona / Page
	Półfabrykat, profil sześcienny Semi-finished products, Rectangular soft blank Werkzeughalter für Sonderausführungen, rechteckig Заготовки	160
	Półfabrykat, profil cylindryczny Semi-finished products, Round soft blank Werkzeughalter für Sonderausführungen, rund Заготовки	160
	Uchwyt poprzeczny prostokątny prawy, krótki Lateral-rectangular holders. Right, short Werkzeughalter mit Vierkant-Queraufnahme rechts, kurz Радиальные державки, правая, короткая	160
	Uchwyt poprzeczny prostokątny lewy, krótki Lateral-rectangular holders. Left, short Werkzeughalter mit Vierkant-Queraufnahme links, kurz Радиальные державки, левая, короткая	161
	Uchwyt poprzeczny prostokątny odwrócony prawy, krótki Lateral-rectangular holders. Overhead, right, short Werkzeughalter mit Vierkant-Queraufnahme Überkopf, rechts, kurz Обратные радиальные державки, правая, короткая	161
	Uchwyt poprzeczny prostokątny odwrócony lewy, krótki Lateral-rectangular holders. Overhead, left, short Werkzeughalter mit Vierkant-Queraufnahme Überkopf, links, kurz Обратные радиальные державки, левая, короткая	161
	Uchwyt poprzeczny prostokątny prawy, długi Lateral-rectangular holders. Right, long Werkzeughalter mit Vierkant-Queraufnahme rechts, lang Радиальные державки, правая, длинная	162
	Uchwyt poprzeczny prostokątny lewy, długi Lateral-rectangular holders. Left, long Werkzeughalter mit Vierkant-Queraufnahme links, lang Радиальные державки, левая, длинная	162
	Uchwyt poprzeczny prostokątny odwrócony prawy, długi Lateral-rectangular holders. Overhead, right, long Werkzeughalter mit Vierkant-Queraufnahme Überkopf, rechts, lang Радиальные державки обратные, правая, длинная	162
	Uchwyt poprzeczny prostokątny odwrócony lewy, długi Lateral-rectangular holders. Overhead, left, long Werkzeughalter mit Vierkant-Queraufnahme Überkopf, links, lang Радиальные державки обратные, левая, длинная	163
	Uchwyt kwadratowy podłużny prawy Longitudinal square holder right Werkzeughalter mit Vierkant-Längsaufnahme rechts Осевые державки, правая	163
	Uchwyt kwadratowy podłużny lewy Longitudinal square holder left Werkzeughalter mit Vierkant-Längsaufnahme links Осевые державки, левая	163

1

2

3

4

5

6

7

8

9

10

11

12

13

14

Strona:

Page:

156

Ilustracja / Picture	Nazwa produktu / Product name	Strona / Page
	<p>Uchwyt kwadratowy podłużny odwrócony prawy Longitudinal square holder. Overhead, right Werkzeughalter mit Vierkant-Längsaufnahme Überkopf, rechts Осевые державки обратные, правая</p>	164
	<p>Uchwyt kwadratowy podłużny odwrócony lewy Longitudinal square holder. Overhead, left Werkzeughalter mit Vierkant-Längsaufnahme Überkopf, links Осевые державки обратные, левая</p>	164
	<p>Uchwyt kwadratowy wielokrotny Square multiple toolholder Werkzeughalter Комбинированные державки</p>	164
	<p>Oprawka do narzędzi z chwytem walcowym z wew. doprowadzaniem chłodzenia Holder for indexable insert drills with internal coolant supply Werkzeughalter Rundaufnahme f. Wendeplattenbohrer mit int. Kühlung Державки для инструмента с цилиндрическим</p>	165
	<p>Oprawka do narzędzi z chwytem walcowym Boring bar holder Bohrstangenhalter Державки для инструмента с цилиндрическим</p>	166
	<p>Uchwyt kwadratowy wielokrotny odwrócony Square multiple toolholder overhead Werkzeughalter Überkopf Комбинированные державки, обратная</p>	167
	<p>Oprawka do narzędzi z chwytem walcowym na tulejki DIN6499 (ER) Collet chuck for collets according to DIN6499, ER type Spannzangenaufnahme Für Spannzangen nach DIN6499, typ ER Державки для цанг er (din 6499)</p>	167
	<p>Oprawka do narzędzi ze stożkiem Morse'a Morse taper holder Morsekegel-aufnahme Державки для осевого инструмента с конусом морзе</p>	167

UCHWYTY NARZĘDZIOWE VDI DIN69880 DO CENTR TOKARSKICH CNC

VDI TOOLHOLDERS FOR CNC LATHES

Rozmieszczenie narzędzi w głowicy rewolwerowej tarczowej

Tools Layout in a rotating
Unterbringung den Werkzeuge in Kreiswerkzeugrevolver
Распределение средств в башне дисков

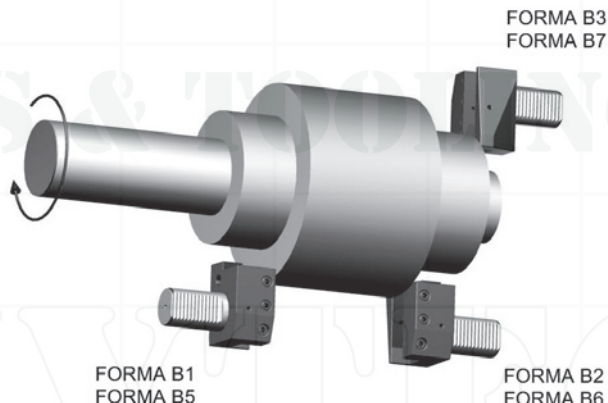
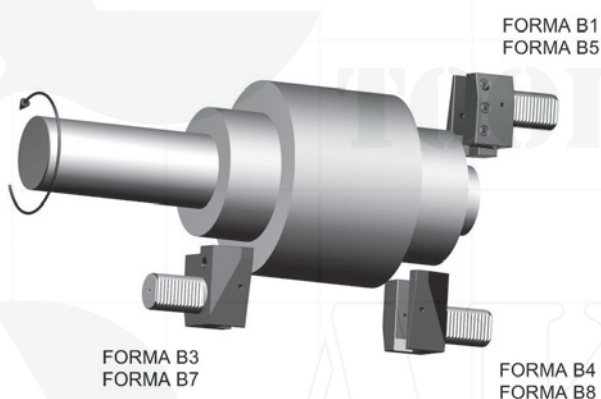

Zastosowanie opravek narzędziowych promieniowych przy lewych obrotach wrzeciona

The use of tool holders with left axis spindle speed
Die Verwendung von Werkzeughaltern mit linken radialen Geschwindigkeit der Spindel
Использование держатели инструмента с левой лучевой скорости шпинделя

Zastosowanie opravek narzędziowych promieniowych przy prawych obrotach wrzeciona

The use of tool holders with right axis spindle speed
Die Verwendung von Werkzeughaltern mit rechten radialen Geschwindigkeit der Spindel
Использование держатели инструмента с правой лучевой скорости шпинделя

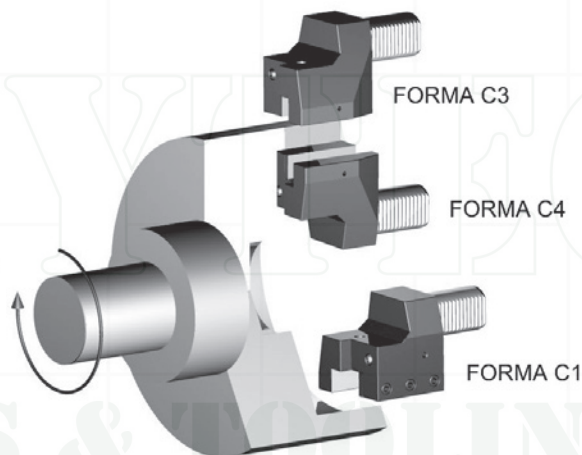
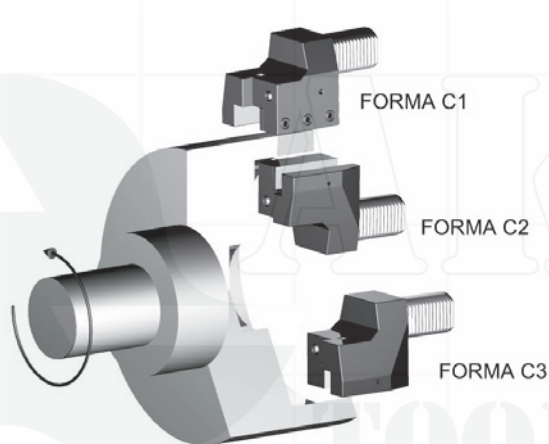

Zastosowanie opravek narzędziowych osiowych przy lewych obrotach wrzeciona

The use of tool holders with left axis spindle speed
Die Verwendung von Werkzeugaufnahmen mit linke Achse Spindeldrehzahl
Использование держатели инструмента с левой скоростью вращения шпинделя оси

Zastosowanie opravek narzędziowych osiowych przy prawych obrotach wrzeciona

The use of tool holders with right axis spindle speed
Die Verwendung von Werkzeugaufnahmen mit rechten Achse Spindeldrehzahl
Использование держатели инструмента с правом скоростью вращения шпинделя оси

- 1
- 2
- 3
- 4
- 5
- 6
- 7
- 8
- 9
- 10
- 11
- 12
- 13
- 14

Specyfikacja techniczna DIN69880 (VDI)

Technical Specifications DIN69880 (VDI)

Technische Daten DIN69880 (VDI)

Технические характеристики DIN69880 (VDI)

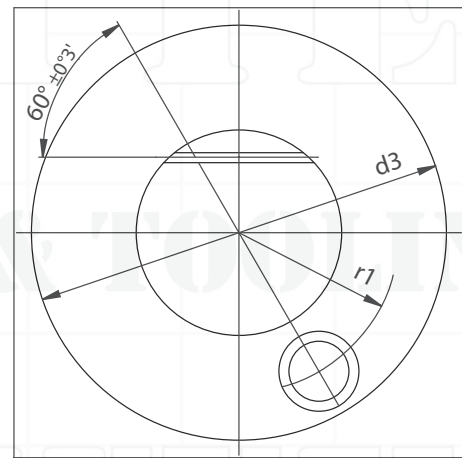
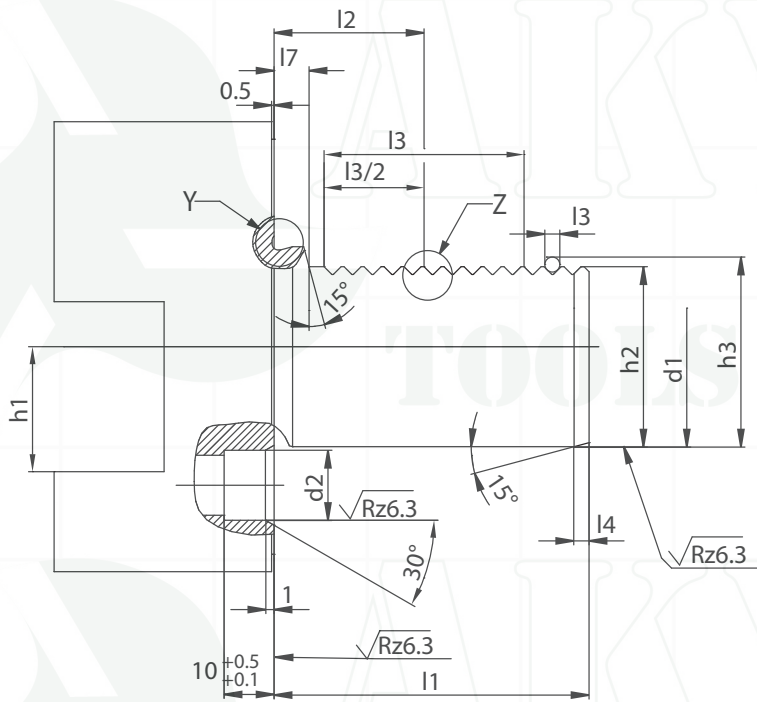
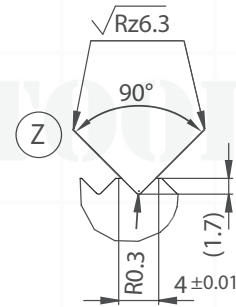
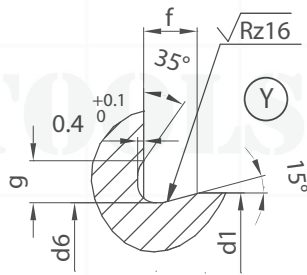

Stożek Holder (DIN69880)	d 1 (mm)	l 1 (mm)	d 2 (mm)	d 3 (mm)	d 6 (mm)	f (mm)	g (mm)	h 1 (mm)	h 2 (mm)	h 3 (mm)	l 2 (mm)	l 3 (mm)	l 4 (mm)	l 7 (mm)	r 1 (mm)
VDI 16	16	32	8 H6	40	15,4	2,0	1,7	12	15	16,92	12,7	16	2	3,5	14,5
VDI 20	20	40	10 H6	50	19,1	2,4	2	16	18	19,92	21,7	24	2	7	18
VDI 25	25	48	10 H6	58	24,1	2,4	2	16	23,5	25,42	21,7	24	2	7	21
VDI 30	30	55	14 H8	68	29,1	2,40	2,00	20	27	28,92	29,7	40	2	7	25
VDI 40	40	63	14 H8	83	38,7	3,70	2,80	25	36	37,92	29,7	40	3	7	32
VDI 50	50	78	16 H8	98	48,7	3,70	2,80	32	45	46,92	35,7	48	3	8	37
VDI 60	60	94	16 H8	123	58,7	4,3	3,7	32	55	56,92	43,7	56	4	10	48

UCHWYTY NARZĘDZIOWE VDI DIN69880 DO CENTR TOKARSKICH CNC

VDI TOOLHOLDERS FOR CNC LATHES

Półfabrykat, profil sześcienny

Semi-finished products, Rectangular soft blank
Werkzeughalter für Sonderausführungen, rechteckig
Заготовки

A1

Kod produktu Order Nr. Bestell-Nr. Код товара	d (mm)	L (mm)	B (mm)	H (mm)
VDI.A1.16.044	16	44	78	44
VDI.A1.20.065	20	65	100	60
VDI.A1.25.075	25	75	100	60
VDI.A1.30.085	30	85	130	76
VDI.A1.40.100	40	100	151	96
VDI.A1.50.125	50	125	160	120

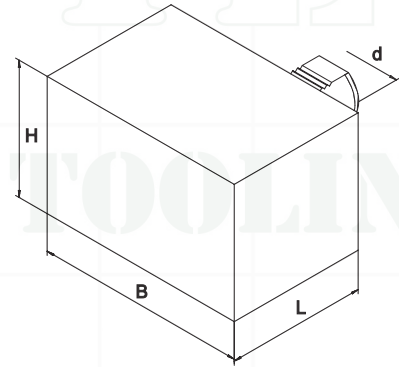

Półfabrykat, profil cylindryczny

Semi-finished products, Round soft blank
Werkzeughalter für Sonderausführungen, rund
Заготовки

A2

Kod produktu Order Nr. Bestell-Nr. Код товара	d (mm)	D (mm)	L (mm)
VDI.A2.16.060	16	40	60
VDI.A2.20.070	20	50	70
VDI.A2.20.160	20	50	160
VDI.A2.25.080	25	58	80
VDI.A2.25.200	25	58	200
VDI.A2.30.100	30	68	100
VDI.A2.30.240	30	68	240
VDI.A2.40.120	40	83	120
VDI.A2.40.200	40	83	200
VDI.A2.40.320	40	83	320
VDI.A2.50.135	50	98	135
VDI.A2.50.220	50	98	220
VDI.A2.50.400	50	98	400
VDI.A2.60.150	60	123	150
VDI.A2.60.250	60	123	250
VDI.A2.60.480	60	123	480

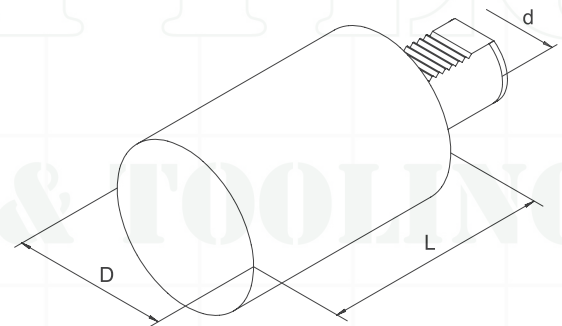

Uchwyt poprzeczny prostokątny prawy, krótki

Lateral-rectangular holders. Right, short
Werkzeughalter mit Vierkant-Queraufnahme rechts, kurz
Радиальные державки, правая, короткая

B1

Kod produktu Order Nr. Bestell-Nr. Код товара	d (mm)	h1 (mm)	a (mm)	a1 (mm)	b (mm)	b1 (mm)	b2 (mm)	h2 (mm)	h3 (mm)	h4 (mm)
VDI.B1.16.12.24	16	12	24	13	42	5	23	10	20	22
VDI.B1.16.12.34	16	12	34	23	42	5	23	10	20	22
VDI.B1.20.16.30	20	16	30	16	55	7	30	12	25	30
VDI.B1.20.16.40	20	16	40	26	55	7	30	12	25	30
VDI.B1.25.16.30	25	16	30	16	55	7	30	12	25	30
VDI.B1.25.16.40	25	16	40	26	55	7	30	12	25	30
VDI.B1.30.20.40	30	20	40	22	70	10	35	16	28	38
VDI.B1.30.20.60	30	20	60	42	70	10	35	16	28	38
VDI.B1.40.25.44	40	25	44	22	85	12,5	42,5	20	32,5	58
VDI.B1.50.32.55	50	32	55	30	100	16	50	25	35	60
VDI.B1.60.32.60	60	32	60	30	125	16	62,5	25	42,5	62,5

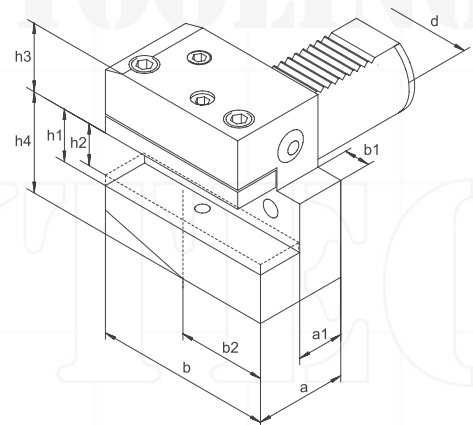

Przy składaniu zamówień e-mailem lub faksem prosimy podawać kody produktów zgodnie z katalogiem.
When ordering by e-mail or fax, please state the product codes according to the catalog.

z magazynu / on stock / ab Lager lieferbar / со склада -
na zapytanie / on request / auf Anfrage / по запросу -

B2

Uchwyt poprzeczny prostokątny lewy, krótki

Lateral-rectangular holders. Left, short
Werkzeughalter mit Vierkant-Queraufnahme links, kurz
Радиальные державки, левая, короткая

Kod produktu Order Nr. Bestell-Nr. Код товара	d (mm)	h1 (mm)	a (mm)	a1 (mm)	b (mm)	b1 (mm)	b2 (mm)	h2 (mm)	h3 (mm)	h4 (mm)
VDI.B2.16.12.24	16	12	24	13	42	5	23	10	20	22
VDI.B2.16.12.34	16	12	34	23	42	5	23	10	20	22
VDI.B2.20.16.30	20	16	30	16	55	7	30	12	25	30
VDI.B2.20.16.40	20	16	40	26	55	7	30	12	25	30
VDI.B2.25.16.30	25	16	30	16	55	7	30	12	25	30
VDI.B2.25.16.40	25	16	40	26	55	7	30	12	25	30
VDI.B2.30.20.40	30	20	40	22	70	10	35	16	28	38
VDI.B2.30.20.60	30	20	60	42	70	10	35	16	28	38
VDI.B2.40.25.44	40	25	44	22	85	12,5	42,5	20	32,5	58
VDI.B2.50.32.55	50	32	55	30	100	16	50	25	35	60
VDI.B2.60.32.60	60	32	60	30	125	16	62,5	25	42,5	62,5

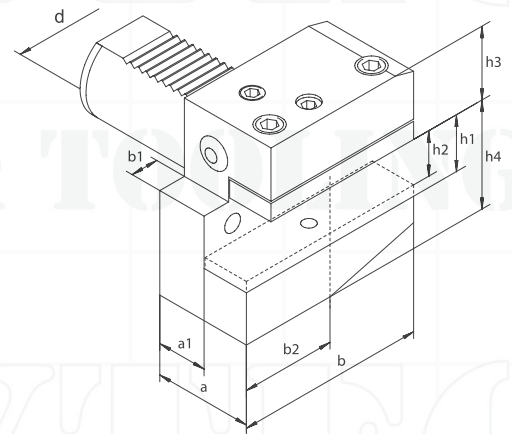

Uchwyt poprzeczny prostokątny odwrócony prawy, krótki

Lateral-rectangular holders. Overhead, right, short
Werkzeughalter mit Vierkant-Queraufnahme Überkopf, rechts, kurz
Обратные радиальные державки, правая, короткая

Kod produktu Order Nr. Bestell-Nr. Код товара	d (mm)	h1 (mm)	a (mm)	a1 (mm)	b (mm)	b1 (mm)	b2 (mm)	h2 (mm)	h3 (mm)	h4 (mm)
VDI.B3.16.12.24	16	12	24	13	42	5	23	10	22	20
VDI.B3.16.12.34	16	12	34	23	42	5	23	10	22	20
VDI.B3.20.16.30	20	16	30	16	55	7	30	12	30	25
VDI.B3.20.16.40	20	16	40	26	55	7	30	12	30	25
VDI.B3.25.16.30	25	16	30	16	55	7	30	12	30	25
VDI.B3.25.16.40	25	16	40	26	55	7	30	12	30	25
VDI.B3.30.20.40	30	20	40	22	70	10	35	16	38	35
VDI.B3.30.20.60	30	20	60	42	70	10	35	16	38	35
VDI.B3.40.25.44	40	25	44	22	85	12,5	42,5	20	48	42,5
VDI.B3.50.32.55	50	32	55	30	100	16	50	25	60	50
VDI.B3.60.32.60	60	32	60	30	125	16	62,5	25	62,5	62,5

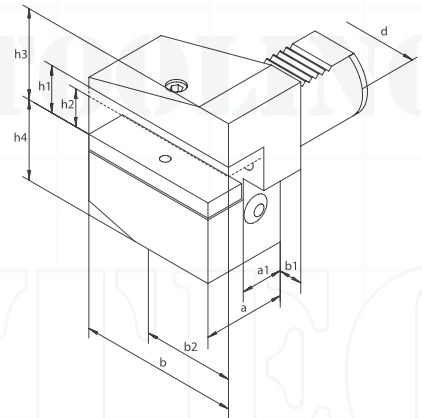

Uchwyt poprzeczny prostokątny odwrócony lewy, krótki

Lateral-rectangular holders. Overhead, left, short
Werkzeughalter mit Vierkant-Queraufnahme Überkopf, links, kurz
Обратные радиальные державки, левая, короткая

Kod produktu Order Nr. Bestell-Nr. Код товара	d (mm)	h1 (mm)	a (mm)	a1 (mm)	b (mm)	b1 (mm)	b2 (mm)	h2 (mm)	h3 (mm)	h4 (mm)
VDI.B4.16.12.24	16	12	24	13	42	5	23	10	22	20
VDI.B4.16.12.34	16	12	34	23	42	5	23	10	22	20
VDI.B4.20.16.30	20	16	30	16	55	7	30	12	30	25
VDI.B4.20.16.40	20	16	40	26	55	7	30	12	30	25
VDI.B4.25.16.30	25	16	30	16	55	7	30	12	30	25
VDI.B4.25.16.40	25	16	40	26	55	7	30	12	30	25
VDI.B4.30.20.40	30	20	40	22	70	10	35	16	38	35
VDI.B4.30.20.60	30	20	60	42	70	10	35	16	38	35
VDI.B4.40.25.44	40	25	44	22	85	12,5	42,5	20	48	42,5
VDI.B4.50.32.55	50	32	55	30	100	16	50	25	60	50
VDI.B4.60.32.60	60	32	60	30	125	16	62,5	25	62,5	62,5

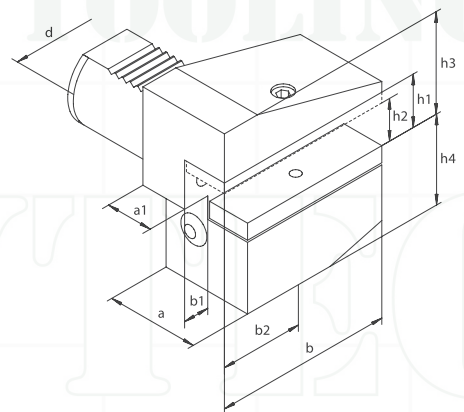

Przy składaniu zamówień e-mailem lub faksem prosimy podawać kody produktów zgodnie z katalogiem.
 When ordering by e-mail or fax, please state the product codes according to the catalog.

z magazynu / on stock / ab Lager lieferbar / со склада - ■
 na zapytanie / on request / auf Anfrage / по запросу - □

Uchwyt poprzeczny prostokątny prawy, długi

Lateral-rectangular holders. Right, long
Werkzeughalter mit Vierkant-Queraufnahme rechts, lang
Радиальные державки, правая, длинная

B5

Kod produktu Order Nr. Bestell-Nr. Код товара	d (mm)	h1 (mm)	a (mm)	a1 (mm)	b (mm)	b1 (mm)	b2 (mm)	h2 (mm)	h3 (mm)	h4 (mm)
VDI.B5.16.12.24	16	12	34	13	58	5	39	10	20	22
VDI.B5.16.12.34	16	12	34	23	58	5	39	10	20	22
VDI.B5.20.16.30	20	16	30	16	75	7	50	12	25	30
VDI.B5.20.16.40	20	16	40	26	75	7	50	12	25	30
VDI.B5.25.16.30	25	16	30	16	75	7	50	912	25	30
VDI.B5.25.16.40	25	16	40	26	75	7	50	312	25	30
VDI.B5.30.20.40	30	20	40	22	100	10	65	16	28	38
VDI.B5.30.20.60	30	20	60	42	100	10	65	16	28	38
VDI.B5.40.25.44	40	25	44	22	118	12,5	75,5	20	32,5	48
VDI.B5.50.32.55	50	32	55	30	130	16	80	25	35	60
VDI.B5.60.32.60	60	32	60	30	145	16	82,5	25	42,5	62,5

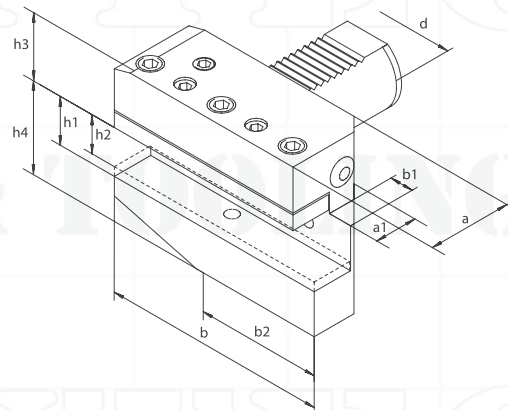

Uchwyt poprzeczny prostokątny lewy, długi

Lateral-rectangular holders. Left, long
Werkzeughalter mit Vierkant-Queraufnahme links, lang
Радиальные державки, левая, длинная

B6

Kod produktu Order Nr. Bestell-Nr. Код товара	d (mm)	h1 (mm)	a (mm)	a1 (mm)	b (mm)	b1 (mm)	b2 (mm)	h2 (mm)	h3 (mm)	h4 (mm)
VDI.B6.16.12.24	16	12	34	13	58	5	39	10	20	22
VDI.B6.16.12.34	16	12	34	23	58	5	39	10	20	22
VDI.B6.20.16.30	20	16	30	16	75	7	50	12	25	30
VDI.B6.20.16.40	20	16	40	26	75	7	50	12	25	30
VDI.B6.25.16.30	25	16	30	16	75	7	50	912	25	30
VDI.B6.25.16.40	25	16	40	26	75	7	50	312	25	30
VDI.B6.30.20.40	30	20	40	22	100	10	65	16	28	38
VDI.B6.30.20.60	30	20	60	42	100	10	65	16	28	38
VDI.B6.40.25.44	40	25	44	22	118	12,5	75,5	20	32,5	48
VDI.B6.50.32.55	50	32	55	30	130	16	80	25	35	60
VDI.B6.60.32.60	60	32	60	30	145	16	82,5	25	42,5	62,5

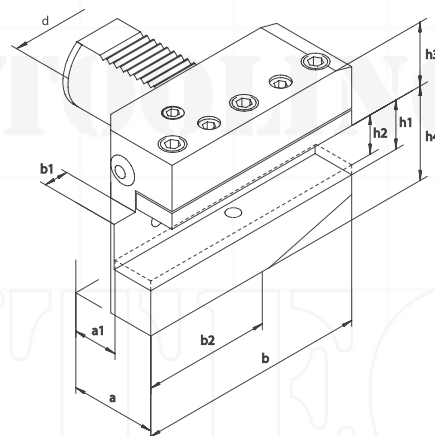

Uchwyt poprzeczny prostokątny odwrócony prawy, długi

Lateral-rectangular holders. Overhead, right, long
Werkzeughalter mit Vierkant-Queraufnahme Überkopf, rechts, lang
Радиальные державки обратные, правая, длинная

B7

Kod produktu Order Nr. Bestell-Nr. Код товара	d (mm)	h1 (mm)	a (mm)	a1 (mm)	b (mm)	b1 (mm)	b2 (mm)	h2 (mm)	h3 (mm)	h4 (mm)
VDI.B7.16.12.24	16	12	24	13	58	5	39	10	22	20
VDI.B7.16.12.34	16	12	34	23	58	5	39	10	22	20
VDI.B7.20.16.30	20	16	30	16	75	7	50	12	30	25
VDI.B7.20.16.40	20	16	40	26	75	7	50	12	30	25
VDI.B7.25.16.30	25	16	30	16	75	7	50	12	30	25
VDI.B7.25.16.40	25	16	40	26	75	7	50	12	30	25
VDI.B7.30.20.40	30	20	40	22	100	10	65	16	38	35
VDI.B7.30.20.60	30	20	60	42	100	10	65	16	38	35
VDI.B7.40.25.44	40	25	44	22	118	12,5	75,5	20	48	42,50
VDI.B7.50.32.55	50	32	55	30	130	16	80	25	60	50
VDI.B7.60.32.60	60	32	60	30	145	16	82,5	25	62,5	62,50

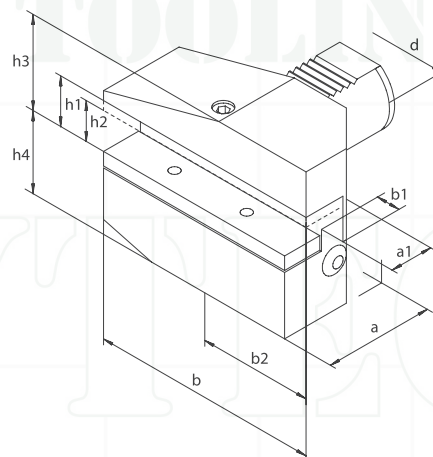

Przy składaniu zamówień e-mailem lub faksem prosimy podawać kody produktów zgodnie z katalogiem.
When ordering by e-mail or fax, please state the product codes according to the catalog.

z magazynu / on stock / ab Lager lieferbar / со склада -
na zapytanie / on request / auf Anfrage / по запросу -

Uchwyt poprzeczny prostokątny odwrócony lewy, długi

Lateral-rectangular holders. Overhead, left, long
 Werkzeughalter mit Vierkant-Queraufnahme Überkopf, links, lang
 Радиальные державки обратные, левая, длинная

B8

Kod produktu Order Nr. Bestell-Nr. Код товара	d (mm)	h1 (mm)	a (mm)	a1 (mm)	b (mm)	b1 (mm)	b2 (mm)	h2 (mm)	h3 (mm)	h4 (mm)
VDI.B8.16.12.24	16	12	24	13	58	5	39	10	22	20
VDI.B8.16.12.34	16	12	34	23	58	5	39	10	22	20
VDI.B8.20.16.30	20	16	30	16	75	7	50	12	30	25
VDI.B8.20.16.40	20	16	40	26	75	7	50	12	30	25
VDI.B8.25.16.30	25	16	30	16	75	7	50	12	30	25
VDI.B8.25.16.40	25	16	40	26	75	7	50	12	30	25
VDI.B8.30.20.40	30	20	40	22	100	10	65	16	38	35
VDI.B8.30.20.60	30	20	60	42	100	10	65	16	38	35
VDI.B8.40.25.44	40	25	44	22	118	12,5	75,5	20	48	42,50
VDI.B8.50.32.55	50	32	55	30	130	16	80	25	60	50
VDI.B8.60.32.60	60	32	60	30	145	16	82,5	25	62,5	62,50

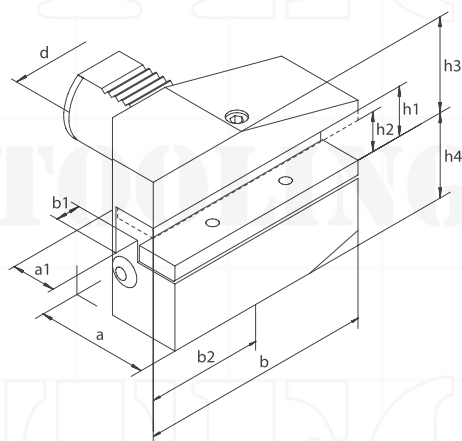

Uchwyt kwadratowy podłużny prawy

Longitudinal square holder right
 Werkzeughalter mit Vierkant-Längsaufnahme rechts
 Осевые державки, правая

C1

Kod produktu Order Nr. Bestell-Nr. Код товара	d (mm)	h1 (mm)	a (mm)	a1 (mm)	a2 (mm)	b (mm)	b1 (mm)	b2 (mm)	h2 (mm)	h3 (mm)	h4 (mm)
VDI.C1.16.12	16	12	43	13	24	44	5	20	10	20	22
VDI.C1.20.16.50	20	16	52	13	27	55	7	30	12	25	30
VDI.C1.20.16.55	20	16	65	26	40	50	7	30	12	25	30
VDI.C1.25.16	25	16	58	19	33	55	7	20	12	25	30
VDI.C1.30.20	30	20	70	17	35	70	10	30	16	28	38
VDI.C1.40.25	40	25	85	21	42,5	85	12,5	30	20	32,5	48
VDI.C1.50.32	50	32	100	26	50	100	16	40	25	35	60
VDI.C1.60.32	60	32	125	33	62,5	125	16	40	25	42,5	62,5

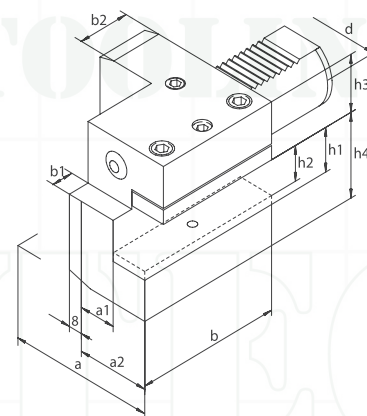

Uchwyt kwadratowy podłużny lewy

Longitudinal square holder left
 Werkzeughalter mit Vierkant-Längsaufnahme links
 Осевые державки, левая

C2

Kod produktu Order Nr. Bestell-Nr. Код товара	d (mm)	h1 (mm)	a (mm)	a1 (mm)	a2 (mm)	b (mm)	b1 (mm)	b2 (mm)	h2 (mm)	h3 (mm)	h4 (mm)
VDI.C2.16.12	16	12	43	13	24	44	5	20	10	20	22
VDI.C2.20.16.50	20	16	52	13	27	55	7	30	12	25	30
VDI.C2.20.16.55	20	16	65	26	40	50	7	30	12	25	30
VDI.C2.25.16	25	16	58	19	33	55	7	20	12	25	30
VDI.C2.30.20	30	20	70	17	35	70	10	30	16	28	38
VDI.C2.40.25	40	25	85	21	42,5	85	12,5	30	20	32,5	48
VDI.C2.50.32	50	32	100	26	50	100	16	40	25	35	60
VDI.C2.60.32	60	32	125	33	62,5	125	16	40	25	42,5	62,5

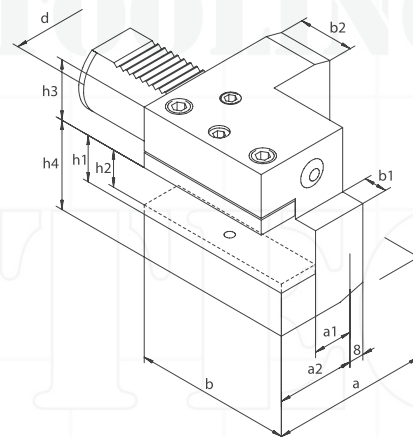

Przy składaniu zamówień e-mailem lub faksem prosimy podawać kody produktów zgodnie z katalogiem.
 When ordering by e-mail or fax, please state the product codes according to the catalog.

z magazynu / on stock / ab Lager lieferbar / со склада - ■
 na zapytanie / on request / auf Anfrage / по запросу - □

UCHWYTY NARZĘDZIOWE VDI DIN69880 DO CENTR TOKARSKICH CNC

VDI TOOLHOLDERS FOR CNC LATHES

Uchwyt kwadratowy podłużny odwrócony prawy

Longitudinal square holder. Overhead, right
 Werkzeughalter mit Vierkant-Längsaufnahme Überkopf, rechts
 Осевые державки обратные, правая

C3

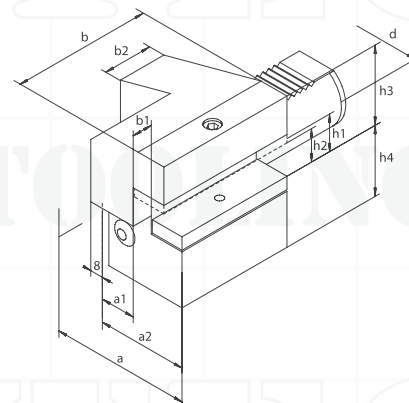

Kod produktu Order Nr. Bestell-Nr. Код товара	d (mm)	h1 (mm)	a (mm)	a1 (mm)	a2 (mm)	b (mm)	b1 (mm)	b2 (mm)	h2 (mm)	h3 (mm)	h4 (mm)
VDI.C3.16.12	16	12	43	13	24	44	5	20	10	22	20
VDI.C3.20.16.50	20	16	52	13	27	55	7	30	12	30	25
VDI.C3.20.16.55	20	16	65	26	40	50	7	30	12	30	25
VDI.C3.25.16	25	16	58	19	33	55	7	20	12	30	25
VDI.C3.30.20	30	20	70	17	35	70	10	30	16	38	35
VDI.C3.40.25	40	25	85	21	42,5	85	12,5	30	20	48	42,5
VDI.C3.50.32	50	32	100	26	50	100	16	40	25	60	50
VDI.C3.60.32	60	32	125	33	62,5	125	16	40	25	62,5	62,5

Uchwyt kwadratowy podłużny odwrócony lewy

Longitudinal square holder. Overhead, left
 Werkzeughalter mit Vierkant-Längsaufnahme Überkopf, links
 Осевые державки обратные, левая

C4

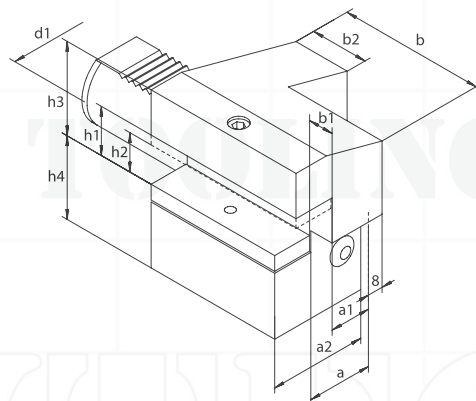

Kod produktu Order Nr. Bestell-Nr. Код товара	d (mm)	h1 (mm)	a (mm)	a1 (mm)	a2 (mm)	b (mm)	b1 (mm)	b2 (mm)	h2 (mm)	h3 (mm)	h4 (mm)
VDI.C4.16.12	16	12	43	13	24	44	5	20	10	22	20
VDI.C4.20.16.50	20	16	52	13	27	55	7	30	12	30	25
VDI.C4.20.16.55	20	16	65	26	40	50	7	30	12	30	25
VDI.C4.25.16	25	16	58	19	33	55	7	20	12	25	25
VDI.C4.30.20	30	20	70	17	35	70	10	30	16	38	35
VDI.C4.40.25	40	25	85	21	42,5	85	12,5	30	20	48	42,5
VDI.C4.50.32	50	32	100	26	50	100	16	40	25	60	50
VDI.C4.60.32	60	32	125	33	62,5	125	16	40	25	62,5	62,5

Uchwyt kwadratowy wielokrotny

Square multiple toolholder
 Werkzeughalter
 Комбинированные державки

D1

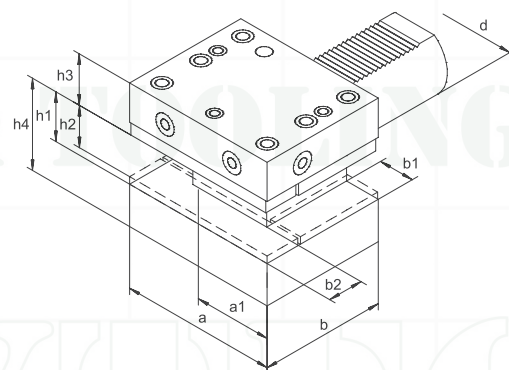

Kod produktu Order Nr. Bestell-Nr. Код товара	d (mm)	h1 (mm)	a (mm)	a1 (mm)	b (mm)	b1 (mm)	b2 (mm)	h2 (mm)	h3 (mm)	h4 (mm)
VDI.D1.25.16	25	16	66	33	48	14	14	12	25	30
VDI.D1.30.20	30	20	76	35	60	18	18	16	28	38
VDI.D1.40.25	40	25	90	42,5	72	21,5	22	20	32,5	48
VDI.D1.50.32	50	32	105	50	85	24	25	25	35	60
VDI.D1.60.32	60	32	115	57,5	110	24,5	25	25	42,5	62,5

Przy składaniu zamówień e-mailem lub faksem prosimy podawać kody produktów zgodnie z katalogiem.
 When ordering by e-mail or fax, please state the product codes according to the catalog.

z magazynu / on stock / ab Lager lieferbar / со склада -
 na zapytanie / on request / auf Anfrage / по запросу -

Oprawka do narzędzi z chwytem walcowym z wew. doprowadzaniem chłodzenia

Holder for indexable insert drills with internal coolant supply
 Werkzeughalter Rundaufnahme f. Wendepplattenbohrer mit int. Kühlung
 Державки для инструмента с цилиндрическим

Kod produktu Order Nr. Bestell-Nr. Код товара	d (mm)	d1 (mm)	d2 (mm)	d3 (mm)	b (mm)	b1 (mm)	b2 (mm)	b3 (mm)	b4 (mm)	h (mm)
VDI.E1.20.10	20	10	35	50	54	18	54	15	35	-
VDI.E1.20.12	20	12	35	50	59	18	54	15	35	-
VDI.E1.20.14	20	14	35	50	59	18	54	15	35	-
VDI.E1.20.16	20	16	36	50	67	18	54	15	35	-
VDI.E1.20.20	20	20	40	50	67	18	54	15	35	-
VDI.E1.20.25	20	25	45	50	71	18	59	17	40	-
VDI.E1.25.20	25	20	40	58	67	22	54	15	35	-
VDI.E1.25.25	25	25	45	58	71	22	59	17	40	-
VDI.E1.25.32	25	32	52	58	85	22	63	17	44	-
VDI.E1.30.10	30	10	35	68	54	22	54	15	35	28
VDI.E1.30.12	30	12	35	68	59	22	54	15	35	28
VDI.E1.30.14	30	14	35	68	59	22	54	15	35	28
VDI.E1.30.16	30	16	36	68	67	22	54	15	35	28
VDI.E1.30.20	30	20	40	68	67	22	54	15	35	28
VDI.E1.30.25	30	25	45	68	71	22	59	17	40	28
VDI.E1.30.32	30	32	52	68	75	22	63	17	44	28
VDI.E1.30.40	30	40	60	68	90	22	73	22	50	28
VDI.E1.40.10	40	10	35	83	67	22	41	20	35	32,5
VDI.E1.40.12	40	12	35	83	59	22	54	15	35	32,5
VDI.E1.40.14	40	14	35	83	59	22	54	15	35	32,5
VDI.E1.40.16	40	16	36	83	67	22	54	15	35	32,5
VDI.E1.40.18	40	18	40	83	67	22	54	15	35	32,5
VDI.E1.40.20	40	20	40	83	67	22	54	15	35	32,5
VDI.E1.40.25	40	25	45	83	75	22	59	17	40	32,5
VDI.E1.40.32	40	32	52	83	75	22	63	17	44	32,5
VDI.E1.40.40	40	40	60	83	90	22	73	22	50	32,5
VDI.E1.40.50	40	50	70	83	-	22	83	24	60	32,5
VDI.E1.50.10	50	10	35	98	-	30	54	15	35	35
VDI.E1.50.12	50	12	35	98	145	30	54	15	35	35
VDI.E1.50.16	50	16	36	98	145	30	54	15	35	35
VDI.E1.50.20	50	20	40	98	67	30	54	15	35	35
VDI.E1.50.25	50	25	45	98	80	30	59	17	40	35
VDI.E1.50.32	50	32	52	98	80	30	63	17	44	35
VDI.E1.50.40	50	40	60	98	90	30	73	22	50	35
VDI.E1.50.50	50	50	70	98	100	30	82	24	60	35
VDI.E1.60.10	60	10	35	123	-	30	54	15	35	42,5
VDI.E1.60.12	60	12	35	123	-	30	54	15	35	42,5
VDI.E1.60.16	60	16	35	123	67	30	54	15	35	42,5
VDI.E1.60.20	60	20	40	123	80	30	54	15	35	42,5
VDI.E1.60.25	60	25	45	123	80	30	59	17	40	42,5
VDI.E1.60.32	60	32	52	123	80	30	63	17	44	42,5
VDI.E1.60.40	60	40	60	123	90	30	73	22	50	42,5
VDI.E1.60.50	60	50	70	123	100	30	83	24	60	42,5

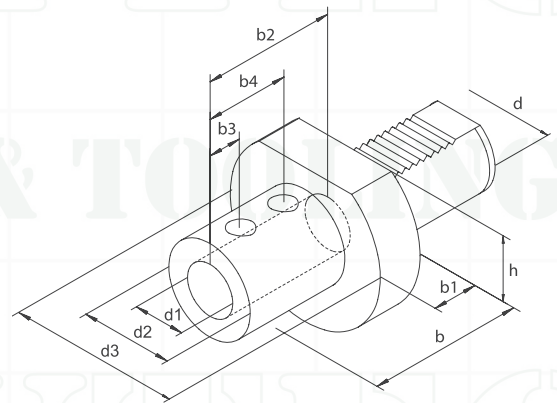

Przy składaniu zamówień e-mailem lub faksem prosimy podawać kody produktów zgodnie z katalogiem.
 When ordering by e-mail or fax, please state the product codes according to the catalog.

z magazynu / on stock / ab Lager lieferbar / со склада - ■
 na zapytanie / on request / auf Anfrage / по запросу - □

UCHWYTY NARZĘDZIOWE VDI DIN69880 DO CENTR TOKARSKICH CNC

VDI TOOLHOLDERS FOR CNC LATHES

E2

Oprawka do narzędzi z chwytem walcowym
Boring bar holder
Bohrstangenhalter
Державки для инструмента с цилиндрическим

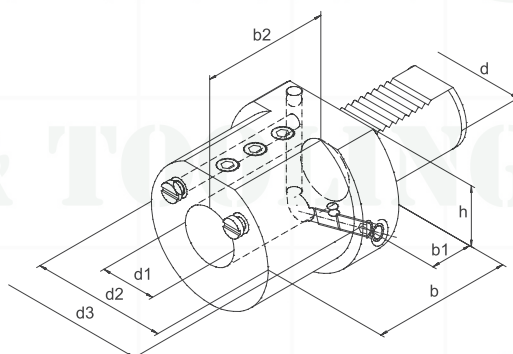

Kod produktu Order Nr. Bestell-Nr. Код товара	d (mm)	d1 (mm)	d2 (mm)	d3 (mm)	b (mm)	b1 (mm)	b2 (mm)	h (mm)
VDI.E2.16.06	16	6	32	40	44	14	34	18
VDI.E2.16.08	16	8	32	40	44	14	34	18
VDI.E2.16.10	16	10	40	40	44	14	34	18
VDI.E2.16.12	16	12	40	40	44	14	34	18
VDI.E2.16.16	16	16	40	40	44	14	34	18
VDI.E2.16.20	16	20	40	40	44	14	34	18
VDI.E2.20.08	20	8	40	50	50	18	41	-
VDI.E2.20.10	20	10	40	50	50	18	41	-
VDI.E2.20.12	20	12	40	50	50	18	41	-
VDI.E2.20.16	20	16	40	50	50	18	41	-
VDI.E2.20.20	20	20	50	50	50	18	41	-
VDI.E2.20.25	20	25	50	50	60	18	41	-
VDI.E2.25.08	25	8	40	58	50	20	41	-
VDI.E2.25.10	25	10	40	58	50	20	41	-
VDI.E2.25.12	25	12	40	58	50	20	41	-
VDI.E2.25.16	25	16	40	58	50	20	41	-
VDI.E2.25.20	25	20	58	58	50	20	41	-
VDI.E2.25.25	25	25	58	58	60	20	41	-
VDI.E2.30.08	30	8	55	68	60	22	51	28
VDI.E2.30.10	30	10	55	68	60	22	51	28
VDI.E2.30.12	30	12	55	68	60	22	51	28
VDI.E2.30.16	30	16	55	68	60	22	51	28
VDI.E2.30.20	30	20	55	68	60	22	51	28
VDI.E2.30.25	30	25	55	68	60	22	51	28
VDI.E2.30.32	30	32	68	68	75	22	51	28
VDI.E2.40.08	40	8	55	83	75	22	61	32,5
VDI.E2.40.10	40	10	55	83	75	22	61	32,5
VDI.E2.40.12	40	12	55	83	75	22	61	32,5
VDI.E2.40.16	40	16	55	83	75	22	61	32,5
VDI.E2.40.20	40	20	55	83	75	22	61	32,5
VDI.E2.40.25	40	25	55	83	75	22	61	32,5
VDI.E2.40.32	40	32	68	83	75	22	61	32,5
VDI.E2.40.40	40	40	83	83	90	22	61	32,5
VDI.E2.50.08	50	8	68	98	90	30	76	35
VDI.E2.50.10	50	10	68	98	90	30	76	35
VDI.E2.50.12	50	12	68	98	90	30	76	35
VDI.E2.50.16	50	16	68	98	90	30	76	35
VDI.E2.50.20	50	20	68	98	90	30	76	35
VDI.E2.50.25	50	25	68	98	90	30	76	35
VDI.E2.50.32	50	32	68	98	90	30	76	35
VDI.E2.50.40	50	40	98	98	90	30	76	35
VDI.E2.50.50	50	50	98	98	100	30	76	35
VDI.E2.60.10	60	10	68	123	90	30	76	42,5
VDI.E2.60.12	60	12	68	123	90	30	76	42,5
VDI.E2.60.16	60	16	68	123	90	30	76	42,5
VDI.E2.60.20	60	20	68	123	90	30	76	42,5
VDI.E2.60.25	60	25	68	123	90	30	76	42,5
VDI.E2.60.32	60	32	68	123	90	30	76	42,5
VDI.E2.60.40	60	40	98	123	90	30	76	42,5
VDI.E2.60.50	60	50	98	123	100	30	76	42,5

1
2
3
4
5
6
7
8
9
10
11
12
13
14

Przy składaniu zamówień e-mailem lub faksem prosimy podawać kody produktów zgodnie z katalogiem.
 When ordering by e-mail or fax, please state the product codes according to the catalog.

z magazynu / on stock / ab Lager lieferbar / со склада -
 na zapytanie / on request / auf Anfrage / по запросу -

Strona:
Page:
166

Uchwyt kwadratowy wielokrotny odwrócony

Square multiple toolholder overhead
Werkzeughalter Überkopf

Комбинируемые державки, обратная

D2

Kod produktu Order Nr. Bestell-Nr. Код товара	d (mm)	h1 (mm)	a (mm)	a1 (mm)	b (mm)	b1 (mm)	b2 (mm)	h2 (mm)	h3 (mm)	h4 (mm)
VDI.D2.25.16	25	16	66	33	48	14	14	12	30	25
VDI.D2.30.20	30	20	76	35	60	18	18	16	38	35
VDI.D2.40.25	40	25	90	42,5	72	21,5	22	20	48	42,5
VDI.D2.50.32	50	32	50	50	85	24	25	25	60	50
VDI.D2.60.32	60	32	60	57,5	110	24,5	25	25	62,5	62,5

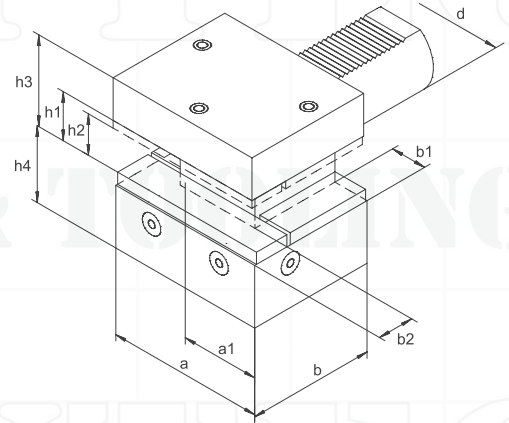

Oprawka do narzędzi z chwytem walcowym na tulejki DIN6499 (ER)

Collet chuck for collets according to DIN6499, ER type

Spannzangenaufnahme Für Spannzangen nach DIN6499, typ ER

Державки для цанг er (din 6499)

E4

Kod produktu Order Nr. Bestell-Nr. Код товара	d (mm)	d1 (mm)	d2 (mm)	b (mm)	b1 (mm)	h (mm)	ER DIN6499	Zakres Range (mm)
VDI.E4.16.ER16	16	40	-	32	-	18	ER16	1 - 10
VDI.E4.16.ER20	20	40	35	32	14	18	ER20	2 - 13
VDI.E4.20.ER16	20	50	-	40	-	-	ER16	1 - 10
VDI.E4.20.ER20	20	50	35	40	-	-	ER20	2 - 13
VDI.E4.20.ER25	20	50	42	40	18	-	ER25	2 - 16
VDI.E4.20.ER32	20	50	50	40	18	-	ER32	3 - 20
VDI.E4.20.ER40	20	50	63	55	26	-	ER40	3 - 30
VDI.E4.30.ER20	20	68	35	55	18	28	ER20	2 - 13
VDI.E4.30.ER25	30	68	42	55	22	28	ER25	2 - 16
VDI.E4.30.ER32	30	68	50	55	22	28	ER32	3 - 20
VDI.E4.30.ER40	30	68	63	55	26	28	ER40	3 - 30
VDI.E4.40.ER25	40	83	42	63	22	32,5	ER25	2 - 16
VDI.E4.40.ER32	40	83	50	63	22	32,5	ER32	3 - 20
VDI.E4.40.ER40	40	83	63	63	22	32,5	ER40	3 - 30
VDI.E4.50.ER40	50	98	63	78	30	35	ER40	3 - 30
VDI.E4.60.ER40	60	123	63	94	30	42,5	ER40	3 - 30

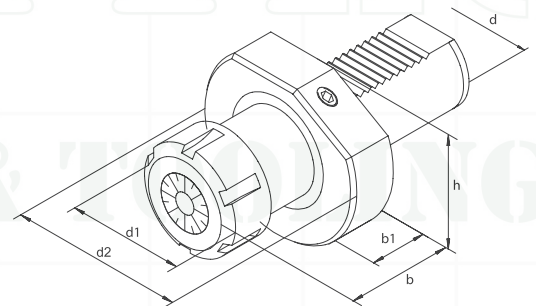

Akcesoria / Accessories / Zubehör / Аксессуары:



Strona/Page: 29



Strona/Page: 29



Strona/Page: 219



Strona/Page: 219

Oprawka do narzędzi ze stożkiem Morse'a

Morse taper holder

Morsekegel-aufnahme

Державки для осевого инструмента с конусом морзе

F

Kod produktu Order Nr. Bestell-Nr. Код товара	d (mm)	Morse	d1 (mm)	d2 (mm)	b (mm)	b1 (mm)	h (mm)
VDI.F.20.MK1	20	MK1	50	-	23	-	-
VDI.F.20.MK2	20	MK2	58	58	23	-	-
VDI.F.30.MK1	30	MK1	68	-	27	-	28
VDI.F.30.MK2	30	MK2	68	58	27	25	28
VDI.F.30.MK3	30	MK3	68	68	50	22	28
VDI.F.40.MK1	40	MK1	83	-	27	22	32,5
VDI.F.40.MK2	40	MK2	83	55	36	22	32,5
VDI.F.40.MK3	40	MK3	83	58	36	22	32,5
VDI.F.40.MK4	40	MK4	83	68	80	22	32,5
VDI.F.50.MK2	50	MK2	98	55	36	30	35
VDI.F.50.MK3	50	MK3	98	58	36	30	35
VDI.F.50.MK4	50	MK4	98	68	50	30	35
VDI.F.50.MK5	50	MK5	98	98	72	35	35
VDI.F.60.MK2	60	MK2	123	55	27	30	42,5
VDI.F.60.MK3	60	MK3	123	58	36	30	42,5
VDI.F.60.MK4	60	MK4	123	68	50	30	42,5
VDI.F.60.MK5	60	MK5	123	98	63	30	42,5

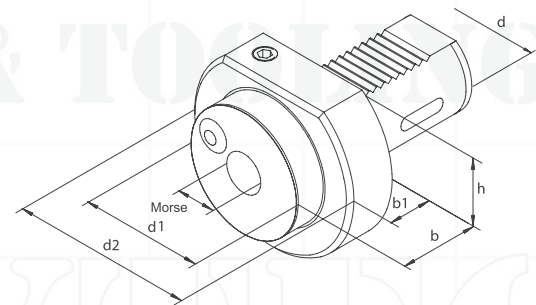

Przy składaniu zamówień e-mailem lub faksem prosimy podawać kody produktów zgodnie z katalogiem.
When ordering by e-mail or fax, please state the product codes according to the catalog.

z magazynu / on stock / ab Lager lieferbar / со склада - ■
na zapytanie / on request / auf Anfrage / по запросу - □